



<https://www.hcfa.cn>

访问官网或扫描二维码下载最新版安装使用说明书

Download the latest installation sheets via the official website or QR code.

浙江禾川科技股份有限公司

浙江省衢州市龙游县工业园区亲善路5号

Zhejiang Hechuan Technology Co.,Ltd

No.5, Qinshan Road, Longyou Industrial Zone, Quzhou City, Zhejiang Province

900101000457

Date 2026-05-29

CN 安装说明

EN Instruction Sheet

1. 安全注意事项 (Safety precautions)

本说明书涉及产品为工业产品，并且均为开放型外壳设计。要求用户使用产品时，务必将产品安装于具有防尘、防潮以及免于电击 / 冲击等意外的控制柜内，并且需要设置保护措施以防止非维护人员不当操作或意外导致设备故障或损坏，造成不可避免的人员风险和财产损失。

The products in this manual are industrial products and are all open-type housing designs. It is essential to install these products within a control cabinet that is safeguarded against dust, moisture, and accidents such as electric shocks or physical impacts. Additionally, protective measures must be taken to prevent malfunctions or damage caused by improper operation or accidents involving non-maintenance personnel. Failure to do so may lead to serious risks to personnel safety and potential loss of property.

更详细的信息请参考 V100 系列硬件手册。

Please refer to the V100 series hardware manual for more detailed information.

2. 命名规则 (Model identification)

V 1 07 S - XXXX

1 2 3 4 6

1	产品系列 (Product series)
V	V系列 (V series)
2	系列型号 (Series type)
1	经济型 (Economy version)

3	屏幕尺寸 (Screen size)
07	7寸 (7 inches)
4	配置 (Configuration)
S	快速版 (Quick version)

5	软件/固件定制代码 (Customized software/firmware code)
X	0~9/A-Z

3. 适用型号 (Applicable model)

名称 (Name)	型号 (Model)	简要说明	Description
触摸屏 (Touch screen)	V107S	7寸经济版, 3路串口通信, 支持WIFI/4G扩展	7-inch economy version, 3-channel serial communication, supports WIFI/4G expansion
网络适配器 (Network adapter)	V300-4G-ADP2	V107S适配的4G扩展模块	4G expansion module specifically for V107S
	V300-WIFI-ADP2	V107S适配V1.200及以上版本的WIFI扩展模块	WIFI expansion modules (V1.200 and above) specifically for V107S

4. 通用电气及环境规格 (General electrical and environmental specifications)

4.1 通用电气规格 (Electrical specifications)

型号 (Model) *1	额定功率: W*2	Rated power: W*2	额定电压	Rated voltage
V107S	3.2	3.2	DC24V, 电压范围: DC19.2~28.8V	DC24V, voltage range: DC19.2~28.8V
V300-4G-ADP2	-	-	由触摸屏供电	Powered by HMI
V300-WIFI-ADP2	-	-		

*注: 1. 所有型号均为安全特低电压输入产品。

2. 此处标识的额定功率为满负载运行时的最大功率。

*Note: 1. All models are featured by the SELV input type.

2. The power rating indicated here is the maximum power under full-load operation.

4.2 环境规格 (Environmental requirements)

项目	Item	规格	Specifications
海拔高度	Altitude	≤2000m	≤2000m
使用环境	Operating environment	控制柜内安装, 开放式及室内使用	Installation within a control cabinet, open-type and indoor use
工作温度	Operating temperature	0~50°C	0~50°C
储存温度	Storage temperature	-20~60°C	-20~60°C
环境湿度	Ambient humidity	10~95%RH (无结露)	10~95%RH (non-condensation)
振动耐受	Vibration resistance	5~150Hz (X/Y/Z方向, 1g/3.5mm位移)	5~150Hz (X/Y/Z direction, 1g/3.5mm displacement)
污染等级	Pollution degree	污染度II	Level 2
冷却方式	Cooling method	自然冷却	Natural air cooling
防护等级	IP rating	前面板 IP65, 后壳 IP20	Front panel: IP65, Back housing: IP20
外壳材质	Enclosure material	阻燃材料	Self-extinguishable

*注: 如果以制造商未规定的方式使用设备, 可能会损坏设备。

*Note: The equipment may be damaged if used in a manner not specified by the manufacturer.

5. 安装说明 (Installation instructions)

5.1 控制柜安装 (Installation within a control cabinet)

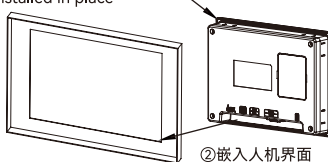
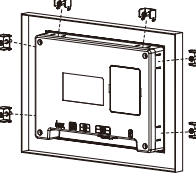
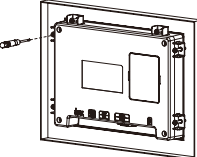
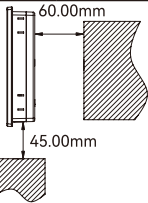
<p>CN</p> <p>确认防水垫圈安装到位后, 将人机界面嵌入控制柜内。先将螺丝装入固定卡扣内, 然后将卡扣底部对准人机界面侧边凹槽, 螺丝头顶住控制柜内侧。以 0.5~0.7N.m 的扭力锁紧螺丝, 请勿超过此扭力, 否则会导致塑料外壳损坏。</p> <p>请参考右侧示意图, 在设备的周围留有足够的空间。</p>	<p>①确认防水垫圈安装到位 Confirm that the waterproof gasket is installed in place</p>  <p>②嵌入人机界面 Embed the HMI into the control cabinet</p>	<p>①将螺丝装入固定卡扣内 Install the screws into the fixing clips</p> <p>②卡扣底部对准侧边凹槽 Align the bottom of the clips with the slots on the sides of the HMI</p> 
<p>EN</p> <p>After confirming the installation of the waterproof gasket, embed the HMI into the control cabinet. Begin by installing the screws into the fixing clips and then align the bottom of the clips with the slots on the sides of the HMI. Place the screw heads against the inner side of the control cabinet. Lock the screws with a torque of 0.5 - 0.7N.m. It is important not to exceed this torque as it can cause damage to the plastic housing. Refer to the diagram on the right to ensure that there is sufficient clearance around the device.</p>	<p>施加 0.5~0.7N.m 的扭力锁紧螺丝 Lock the screws with a torque of 0.5~0.7N.m</p> 	

5.2 适配器拆装 (Adapter mounting and dismounting)

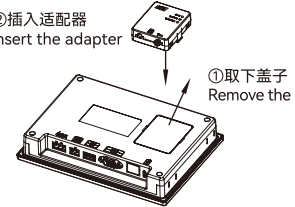
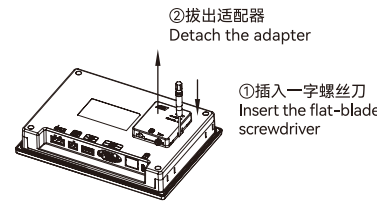
<p>安装适配器时，将人机界面背面的盖子取下，然后将适配器插入，轻拽适配器，适配器不松动即成功安装；拆卸适配器时，将一字螺丝刀插入侧边凹槽，然后将适配器拔出。</p>	<p>②插入适配器 Insert the adapter</p> <p>①取下盖子 Remove the cover</p> 	<p>②拔出适配器 Detach the adapter</p> <p>①插入一字螺丝刀 Insert the flat-blade screwdriver</p> 
<p>CN During mounting, remove the cover on the back of the HMI first, then insert the adapter, and gently tug the adapter, if the adapter does not loosen, the installation is finished successfully. During dismounting, insert the flat-blade screwdriver into the side notch, and then detach the adapter.</p> <p>EN</p>		

5.3 可拆卸端子拆装 (Removable terminal block mounting and dismounting)

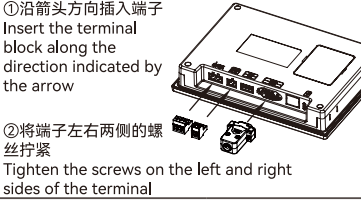
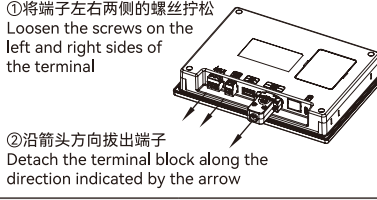
<p>CN 可拆卸端子拆装如右图所示。</p>	<p>①沿箭头方向插入端子 Insert the terminal block along the direction indicated by the arrow</p> <p>②将端子左右两侧的螺丝拧紧 Tighten the screws on the left and right sides of the terminal</p> 	<p>①将端子左右两侧的螺丝拧松 Loosen the screws on the left and right sides of the terminal</p> <p>②沿箭头方向拔出端子 Detach the terminal block along the direction indicated by the arrow</p> 
<p>EN The mounting and dis-mounting of the removable terminal block are shown in the figures on the right side.</p>		

5.4 线缆拆装 (Cable connecting and disconnecting)

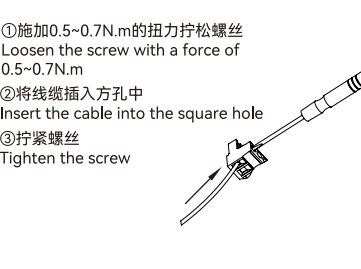
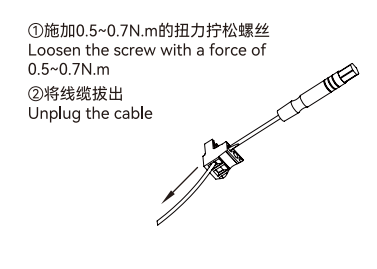
<p>CN 安装线缆时，将一字螺丝刀对准可拆卸端子螺丝，施加0.5~0.7N.m的扭力拧松螺丝，将准备好的线缆插入到方孔中，拧紧螺丝，拔出一字螺丝刀，轻拽线缆，线缆不松动即成功完成配线；反之即可取出线缆。端子规格及配线示意图如右图所示。</p> <p>EN During connecting, align the flat-blade screwdriver with the screw and loosen it with a force of 0.5~0.7N.m. Then insert a cable into the square hole, and then tighten the screw with the screwdriver. Gently tug the cable after pulling out the screwdriver. If the cable is secured firmly, then the connection is finished. The reverse is the procedure for unplugging the cable. The terminal specifications and wiring diagram are shown in the right figure.</p>	<p>①施加0.5~0.7N.m的扭力拧松螺丝 Loosen the screw with a force of 0.5~0.7N.m</p> <p>②将线缆插入方孔中 Insert the cable into the square hole</p> <p>③拧紧螺丝 Tighten the screw</p> 	<p>①施加0.5~0.7N.m的扭力拧松螺丝 Loosen the screw with a force of 0.5~0.7N.m</p> <p>②将线缆拔出 Unplug the cable</p> 
--	--	--

模块端子 (Terminal)	线径范围: AWG (Wire width)	剥线长度: mm (Wire stripping length)	扭力:N.m (Torsion force)	线径范围 Wire width
3Pin DC24V 电源端子 (3Pin DC24V power supply terminal)	24~12	8~9	0.5~0.7	剥线长度 Wire stripping length
2Pin RS485 端子 (2Pin RS485 terminal)				

警告：只能使用75°C铜导线。
Warning: Use only a copper conductor that is 75°C.
Attention: Utilisez uniquement un conducteur en cuivre à 75°C.

6. 接口和尺寸说明 (Interface and dimension description)

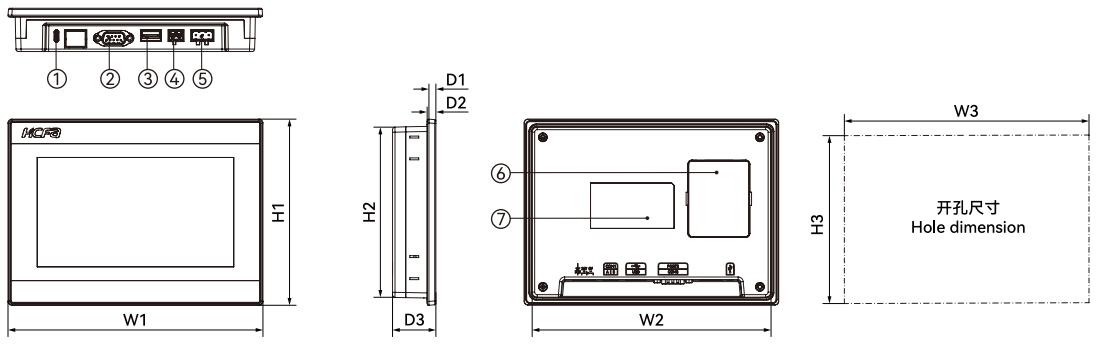

序号 (No.)	名称	Name	功能	Function
1	USB-C接口	USB-C interface	连接电脑，下载程序	Supports connecting to the computer and downloading programs
2	PORT2通讯接口	PORT2 communication interface	支持RS232/RS422/RS485通讯	Supports RS232/RS422/RS485 communication
3	USB-A接口	USB-A interface	支持U盘导入/导出程序与文件读写	Supports U disk program import/export and file reading/writing
4	COM1串行通讯接口	COM1 serial communication interface	支持RS485通讯	Support RS485 communication
5	DC24V电源端子	DC24V power supply terminal	DC24V供电接口	DC24V power supply interface
6	网络适配器接口	Network adapter interface	连接网络适配器	Connect network adapter
7	标签	Label	显示触摸屏型号，规格参数、内部序列号等基本信息	Displays the basic information including touch screen model, specification parameters, and internal serial number

型号 (Model)	外形尺寸 (Dimension) :mm									重量 (Weight) :g
	W1	W2	W3	H1	H2	H3	D1	D2	D3	
V107S	200.0	188.6	192.0	146.0	134.6	138.0	5.5	6.6	34.0	460 approx.

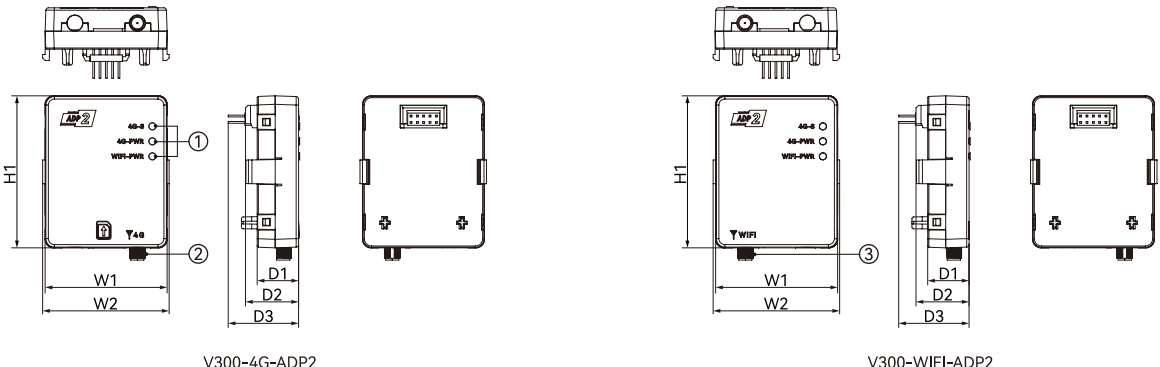

序号 (No.)	名称	Name	功能	Function
1	模块状态指示灯	Module status indicator	显示适配器运行状态	Displays the running status of the adapter
2	4G天线接口	4G antenna interface	连接4G天线, 增强无线信号	Connects the 4G antenna to enhance the wireless signal
3	WIFI天线接口	WIFI antenna interface	连接WIFI天线, 增强无线信号	Connects to the WIFI antenna to enhance the wireless signal

型号 (Model)	外形尺寸 (Dimension) :mm						重量 (Weight) :g
	W1	W2	H1	D1	D2	D2	
V300-4G-ADP2	48.80	50.60	60.80	16.55	21.22	28.14	40 approx.
V300-WIFI-ADP2							

7. 指示灯说明 (Indicator description)

丝印 (Screen printing)	指示灯含义 (Indicator meaning)	颜色 (Color)	状态	Status	说明	Description
V300-4G-ADP / V300-WIFI-ADP						
4G-S*	4G 信号 (4G signal)	绿色 (Green)	熄灭	Not lit	无信号	No signal
			闪烁1	Blinking I	正在搜网	Finding the internet
			闪烁2	Blinking II	待机	Stand-by
4G-PWR	4G 适配器电源 (4G adapter power)	绿色 (Green)	熄灭	Not lit	未供电	No power supply
			常亮	Lit	供电正常	Normal power supply
WIFI-PWR	WIFI 适配器电源 (WIFI adapter power)	绿色 (Green)	熄灭	Not lit	未供电	No power supply
			常亮	Lit	供电正常	Normal power supply

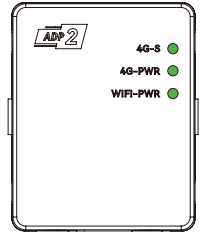

指示灯闪烁频率如下图所示:

The indicator blinking frequency is shown below.

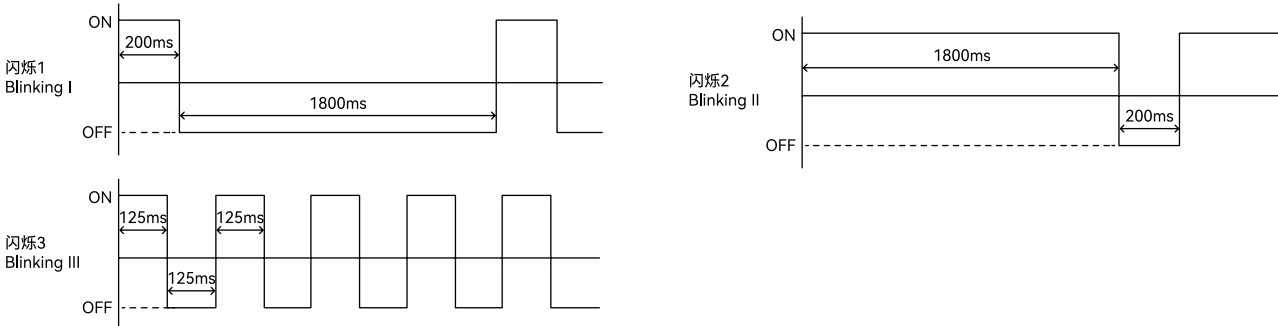

8. 端子及配线说明 (Terminal and wiring description)

3Pin DC24V电源端子说明 (3Pin DC24V power supply terminal description)		接线 (Wiring)
0V		
24V		
FG		

通讯端子说明 (Communication terminal description)				
COM1 串行通讯接口 (COM1 serial communication interface)		PORT2通讯接口 (PORT2 communication interface)		
	Pin	信号 (Signal)		
	1	RS485 (COM1)		
	2	A	B	
	Pin	信号 (Signal)		
	1	RS485 (COM2)	RS422 (COM2)	RS232 (COM3)
	2	B	Rx-	RxD
	3			TxD
	4		Tx-	
	5	SG	SG	SG
	6	A	Rx+	
	7			
	8			
9		Tx+		

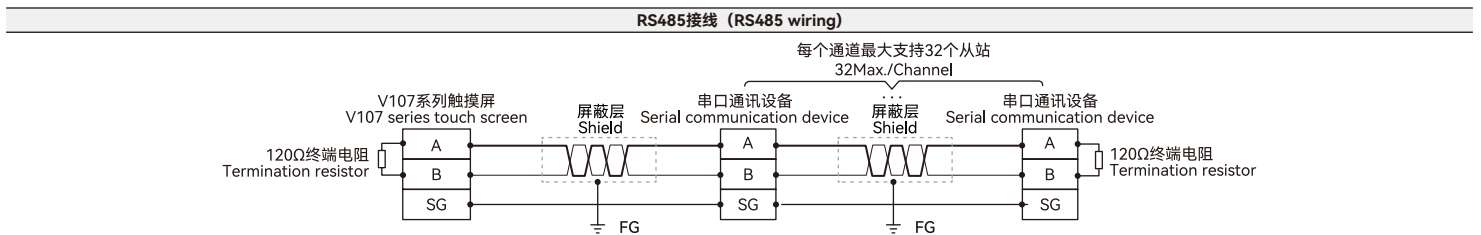

RS232接线 (RS232 wiring)

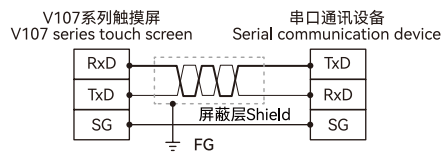

RS422接线 (RS422 wiring)

